

Flight Design
AIRCRAFT OPERATING INSTRUCTIONS
CTSW

(CTSW / CTSW-2006 / CTSW Classic / CTSW Advanced)



SERIAL NUMBER: _____

THIS DOCUMENT AND THE TECHNICAL DATA HEREON DISCLOSED ARE PROPRIETARY TO FLIGHT DESIGN AND SHALL NOT BE USED, RELEASED, OR DISCLOSED IN WHOLE OR IN PART WITHOUT EXPRESS WRITTEN PERMISSION FROM FLIGHT DESIGN

1 Table of Contents

1	Table of Contents	iii
2	General Information	2-1
3	Airplane and Systems Descriptions	3-1
3.1	Engine: Rotax® 912 Series	3-1
3.2	Propeller	3-2
3.3	Fuel and fuel capacity	3-2
3.4	Oil	3-3
3.5	Operating weights and loading (occupants, baggage, fuel, ballast)	3-4
3.6	Structures and Systems Description	3-5
4	Operating Limitations	4-1
4.1	Stalling speeds at maximum takeoff weight (<i>VS1</i> and <i>VS0</i>)	4-1
4.2	Flap extended speed range (<i>VS0</i> to <i>VFE</i>)	4-1
4.3	Maximum maneuvering speed (<i>VA</i>)	4-1
4.4	Never exceed speed (<i>VNE</i>)	4-2
4.5	Crosswind and wind limitations	4-2
4.6	Service Ceiling	4-2
4.7	Load factors	4-2
4.8	Maneuvers	4-3
4.9	Other limitations	4-3
5	Weight and Balance Information	5-1
5.1	Installed equipment list	5-1
5.2	Center of gravity (CG) range and determination	5-1
6	Performance	6-1
6.1	Takeoff distance	6-1
6.2	Best rate of climb	6-1
6.3	Best angle of climb	6-1
6.4	Cruise speed	6-1
6.5	RPM	6-1
6.6	Fuel consumption	6-1
7	Emergency Procedures	7-1
8	Normal Procedures	8-1
8.1	Preflight	8-1
8.2	Engine start	8-3
8.3	Taxiing	8-3
8.4	Normal takeoff	8-4
8.5	Climb	8-4
8.6	Cruise	8-4
8.7	Descent	8-4
8.8	Before landing	8-4
8.9	Normal landing	8-4
8.10	After landing	8-5
8.11	Shut down	8-5
8.12	Short field takeoff procedure	8-5
8.13	Balked landing procedure	8-5

8.14	Information on stalls, spins and other useful pilot information	8-5
9	Aircraft Ground Handling and Servicing.....	9-1
9.1	Servicing fuel, oil and coolant.....	9-1
9.2	Towing (moving) and tie-down instructions	9-1
10	Required Placards and Markings	10-1
10.1	Airspeed indicator range markings	10-1
10.2	Operating limitations on instrument panel	10-1
10.3	Passenger Warning	10-1
10.4	“NO INTENTIONAL SPINS”	10-2
10.5	Miscellaneous placards and markings.....	10-2
11	Supplementary Information	11-1
11.1	Familiarization flight procedures.....	11-1
11.2	Pilot operating advisories	11-1
12	List of amendments.....	12-1
	Appendix 1. Equipment List	1
	Appendix 2. Variants of instrument panels.....	2
	Appendix 3. Samples of the Weight & Balance and Equipment List.....	10

Note: In accordance FAR 21.190 Flight Design has established Aircraft Operating Instructions for the CTSW. The content and format is defined by ASTM standard F2245 and supplemented as deemed necessary by the manufacturer.

2 General Information

Read this before your first flight!

Each pilot must be familiar with the contents of the Aircraft Operating Instructions Manual and abide by all placards, limitations and checklists. Additionally, all Service Directives must be complied with and the Maintenance and Inspections Procedures manual must be used for all maintenance. For maintenance of the Rotax® engine, the BRS emergency parachute system and other installed equipment refer to the original manufacturers' manuals.

Flight Design CTSWs are delivered worldwide, and comply with a variety of Light Sport airworthiness standards. All configurations are equipped with non-certified engines that meet ASTM standard F2339. Unless otherwise specified, the information given is common to all configurations. Where different, the information is given in the appropriate appendices and supplements.

The Flight Design CTSWs delivered in the U.S.A. are built to conform to the U.S. Light Sport Pilot rules and are intended for Day/VFR use.

This manual is for guidance when operating a CTSW aircraft and is not intended to substitute for any required training received from an appropriately rated flight instructor.

Manufacturer

Flight Design GmbH
Sielminger Str. 65
D – 70771 L.-Echterdingen

Basic description

The CTSW is a conventional two seat high-wing aircraft with three-axis controls.

The wings are fully cantilevered, incorporate integral fuel tanks, pushrod actuated ailerons and slotted type flaps that extend downwards for slow speed flight, and reflex upwards for cruise flight.

The aircraft is equipped with an all-moving stabilator with a trim tab and tricycle landing gear with a steerable nose-wheel.

The primary structures are made of carbon fiber reinforced plastic.

Views and dimensions, inches (mm)

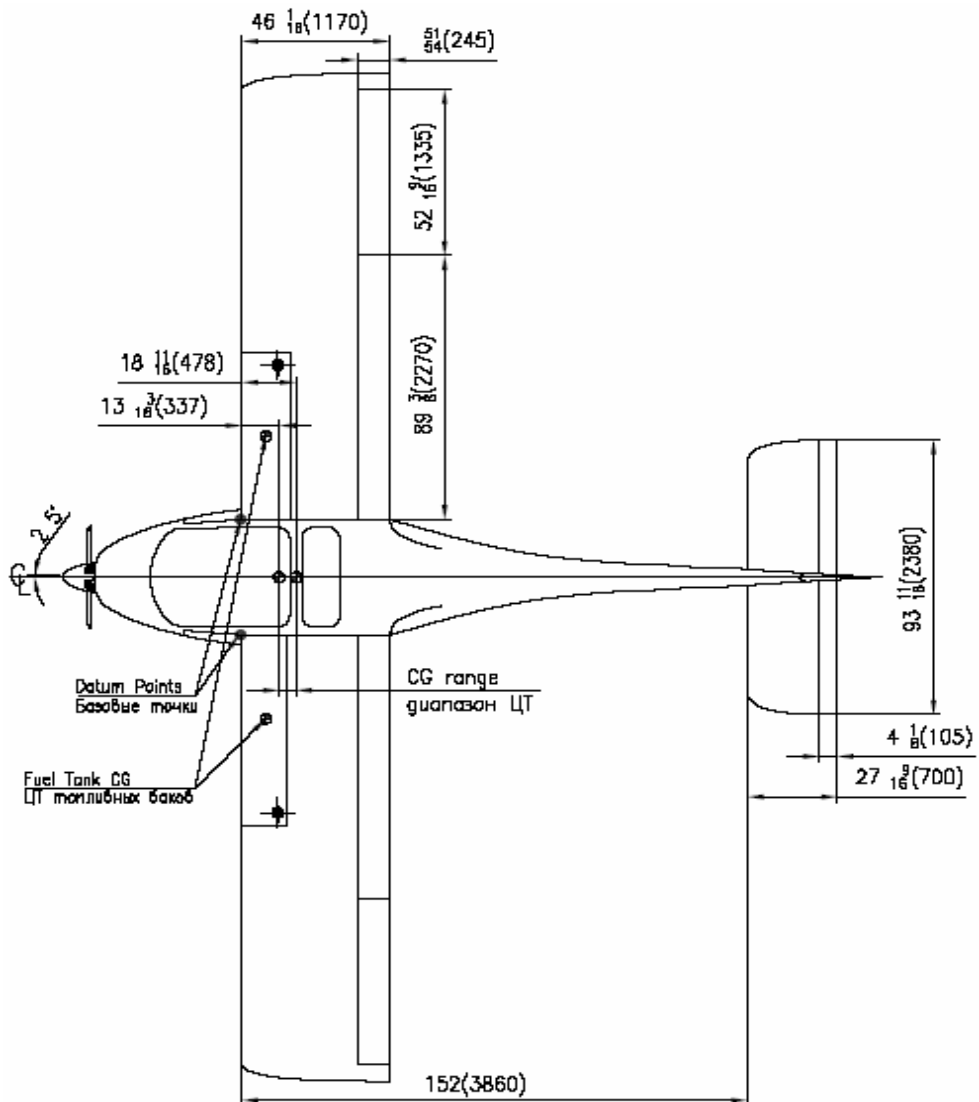
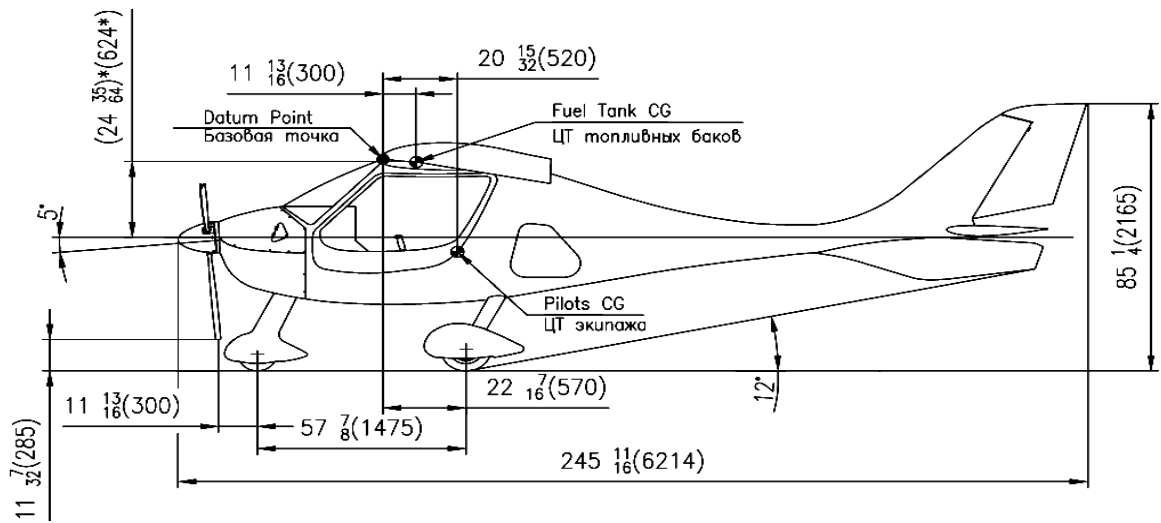

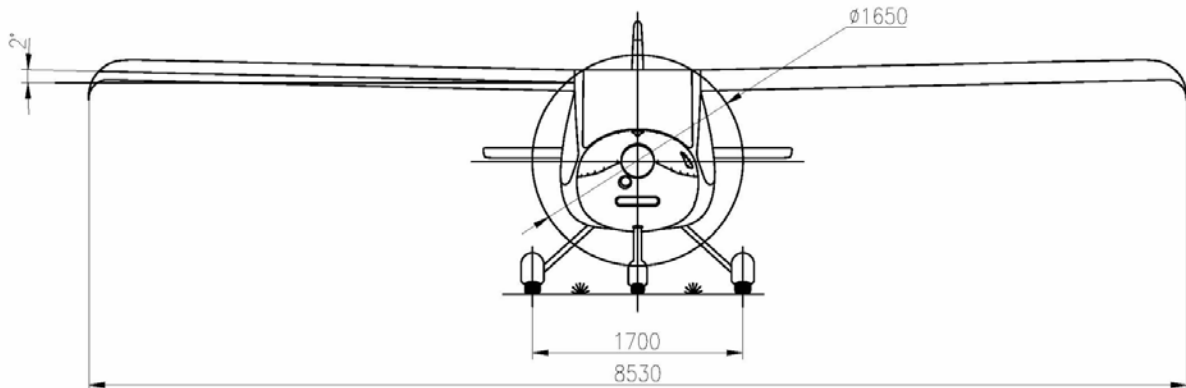
Geometrical parameters

Geometry, mm / inch		
Max. length	6214	244.6
Max. height	2165	85.3
Areas, m² / ft²		
Wing	9.98	107.4
Stabilator	1.65	17.75
Vertical tail	1.32	14.20
Wing span, m / inch	8.53	335.8
Aspect ratios		
Wing	7,29	
Stabilator	3,40	

Page Intentionally Left Blank

3 Airplane and Systems Descriptions

3.1 Engine: Rotax® 912 Series

Description

The standard engine is a Rotax 912 UL2, a four cylinder, horizontally opposed, normally aspirated four stroke engine that incorporates air cooled cylinders with liquid cooled heads.

For the optional engines please see Appendix 1 (Equipment List)

Limitations

	ROTAX 912 UL2	ROTAX 912 ULS
Take-off performance: (at 5.800 RPM, max 5 min)	59.6 KW / 81 HP	73.5 KW / 100 HP
Max. continuous performance (at 5.500 RPM)	58 KW / 79 HP	69 KW / 95 HP
Min RPM before take-off, RPM	4.400	4.500
Max RPM before take-off, RPM	5.500	
Max cylinder head temperature	120 °C 248 F	

For a complete description of the engine and limitations see the Rotax 912 Operator's Manual

3.2 Propeller

For a complete description of the propeller see Operator's Manual for appropriate propeller

Applicability

	CTSW Classic Light	CTSW Classic	CTSW Advanced
Neuform TXR-65, 2-blade	●		
Neuform CR3-65, 3-blade		●	●
Kaspar, 3-blade in-flight adjustable		●*	●*

* - available as an option

For the optional propellers please see Appendix 1 (Equipment List)

3.3 Fuel and fuel capacity

The fuel valve is purely on/off and has to be in the appropriate maximum position. This engine does not have a mixture valve or require leaning.

Fuel specification: Premium Automotive Unleaded per ASTM D 4814, minimum AKI 91 for Rotax 912ULS.
 SUPER leaded, DIN 51600, ONORM C 1103
 EURO-SUPER ROZ 95 unleaded, DIN 51603, ONORM 1101
 SUPER PLUS ROZ 98 unleaded, DIN 51607, ONORM 1100
 AVGAS 100 LL.

ATTENTION! AVGAS loads the valve seats with high lead content and forms more combustion chamber deposits and should be used only in case of steam blast problems or MOGAS failing.

Each wing has an integral fuel tank with a capacity of 65l / 17 U.S. gallons of which 62l / 16.5 gallons are usable.

The total fuel capacity is 130l / 34 U.S. gallons of which 124l / 33 gallons are usable.

For complete fuel specifications see the Rotax 912 Operator's Manual

3.4 Oil

Only brand-name semi-synthetic or full synthetic 4-stroke motorcycle oil should be used.

	ROTAX 912 UL2	ROTAX 912 ULS
Oil, normal operating pressure (below 3.500 RPM)	2.0 – 5.0 bar 29 – 73 psi	
Oil, min operating pressure (above 3.500 RPM)	0.8 bar 12 psi	
	on very cold start momentarily 7 bar allowed	
Min/max temperature measured at the oil inlet of the engine	50 / 130 °C 120 / 266 °F	
Optimum operating temperature	90-110 °C 190-230 °F	
Oil capacity	3.0 l, min 2.0 l 6.4 liq pt, min 4.2 liq pt	
Max oil consumption, L per hour / liq pt per hour	0.06 / 0.13	

The engine is equipped with a friction clutch to guard against sudden propeller stoppage: for this reason, oils with friction modifiers or additives that favor clutch slippage should not be used.

Diesel engine oils are unsuitable because of their lower temperature tolerances.

For oil change intervals see the Maintenance and Inspection Procedures Manual.

Note: If the engine is primarily run on AVGAS, more frequent oil changes will be required because of possible lead build-up.

For complete oil specifications see the Rotax 912 Operator's Manual

3.5 Operating weights and loading (occupants, baggage, fuel, ballast)

Operating weights

	LSA registration			
	USA		Australia	
	kg	lbs	kg	lbs
Max. take-off weight	600	1323	544 / 600	1199 / 1323
Empty plane	314*	693*	303	668
Typical payload	297	654	241 / 297	531 / 654

* - with BRS 1350 HS

	BFU / LTF-UL registration	
	kg	lbs
Max. take-off weight	472.5	1042
Empty plane	268	590
Typical payload	180 / 114.5*	396 / 252*

* - with full tanks

	BCAR Section S registration	
	kg	lbs
Max. take-off weight	450	922
Empty plane	265	584
Typical payload	185	407

Loading

	LSA registration	BFU / LTF-UL registration	BCAR(S) registration
Maximum weight per seat	118 kg 260 lbs	100 kg 220 lbs	100 kg 220 lbs
Maximum baggage weight per side	25 kg 55 lbs		
Minimum single pilot weight	54 kg 120 lbs	70 kg 155 lbs	55 kg 122 lbs
Maximum fuel weight	93 kg 205 lbs		
Minimum fuel weight	9 kg 20 lbs	8 kg 18 lbs	13 kg 29 lbs

3.6 Structures and Systems Description

Fuselage

The fuselage of the CTSW is made of multiple layers of carbon fiber and aramid (Kevlar®) laminated over a dense foam core creating a sandwich structure. The cabin can resist loads from all sides. This provides superior pilot and passenger crash protection and low structural weight.

Wings

The cantilevered wing of the CTSW plugs into 4 hard points at the top of the cabin for attachment to the fuselage. The overlapping spars resist lift loads. The main spar caps are solid carbon fiber wrapped with S glass fibers over a dense Rohacell core. The wing “skin” is a carbon fiber sandwich. The ribs are molded carbon fiber and bonded into place.

Wingtips

The wingtips of the CTSW are highly developed drooped type. They reduce stall speed, improve stability and low speed control of the CTSW.

Fuel system

Fuel is gravity fed to the engine from two integral wing tanks. The total capacity is 130l / 34 U.S. gallons. The usable fuel quantity is 124l / 33 U.S. gallons.

The operation of the fuel valve does not allow the ignition key to be inserted unless the fuel valve is in the “ON” position.

Electric system

The Rotax 912 series of engines are equipped with a “Lighting Coil” type alternator and a rectifier-regulator that converts and regulates the output of the alternator to a nominal 13.5V – 14.2V 250W (roughly 18A).

The battery for the electric starting system is 12V sealed, AGM type.

The dual ignition system is a CDI (capacitive discharge).

Landing gear

The landing gear of the CTSW is of the tricycle type. The nose wheel is steerable through a direct link to the rudder pedals. The main gear legs are heavy duty machined aluminum rods.

Brakes

Hydraulic disk type, actuated through a handbrake lever. Parking brake is set by simultaneous use of the brake lever and parking brake valve.

Control surfaces

The movable surfaces of the CTSW are of aramid-foam-aramid, carbon-foam-aramid, carbon-foam-carbon sandwiches with carbon fiber spars and attachment points.

Rudder

The rudder is of a conventional type and it is aerodynamically balanced and is operated through foot pedals and cables.

Stabilator

The stabilator is an all-moving type stabilizer with a counter-weight and anti servo/trim tab. It is actuated through a flexible push pull cable connected to the dual control sticks.

Ailerons

The Frise type ailerons are controlled with push pull tubes and rod bearings and droop automatically with selection of the flaps.

Flaps

The flaps are of the slotted type, and a pre-selector switch is used to position the flaps from -6° (or -12° for CT-LSA Australia) to $+40^\circ$. The position of the flaps is indicated on the control panel. The flaps are protected by limit switches at the end limits.

Pitch Trim

Pitch trim is activated through a control wheel located adjacent to throttle quadrant, and acts upon trim tab on the stabilator.

Aileron Trim

Aileron trim is activated through a control wheel located on the console between the pilot seats.

Rudder Trim System

Rudder trim is activated through a control wheel located on the cabin bulkhead above the console and between the pilot seats.

BRS Parachute system

Rocket deployed emergency parachute system. The system is actuated through the red "T" handle located on the cabin bulkhead between the pilot seats. The T handle is secured on the ground with a tagged safety pin. The pin is removed for flight operations. To deploy the parachute, the T handle is pulled out fully to the stop.

Autopilot

Autopilot is an optional equipment. The available autopilots are Digiflight II Series.

- CT Pilot 1 Axis, Digiflight II FP basis (Aileron, later upgrade possible);
- CT Pilot 2 Axis, Digiflight II FP basis (Aileron & Stabilizer, later upgrade possible);
- CT Pilot 2 Axis + vertical speed, Digiflight II FP VS basis (Aileron & Stabilizer with vertical steering).

For a complete description and operating information of the autopilot see Operating Handbook for Digiflight II Series autopilots, TruTrak Flight Systems.

CTSW Classic Light Standard Instrument Panel*

Symbolic notations

- 1 Ignition lock / start
- 2 Fuel valve
- 3 12V outlet
- 4 Switch panel
- 5 Flap position indicator
- 6 Flap circuit breaker
- 7 Flap switch
- 8 Main circuit breaker 30A
- 9 Main circuit breaker 25A
- 10 Air speed indicator
- 11 Three pointer altimeter
- 12 Circuit breakers
- 13 Slip & bank indicator
- 14 Cabin heating
- 15 Carburettor heating
- 16 Cockpit light
- 17 Instrument light

* - instrument panels can be chosen from the list (please see Appendix 2) with accordance to the list of the instruments from the Customer Order

Control Quadrant

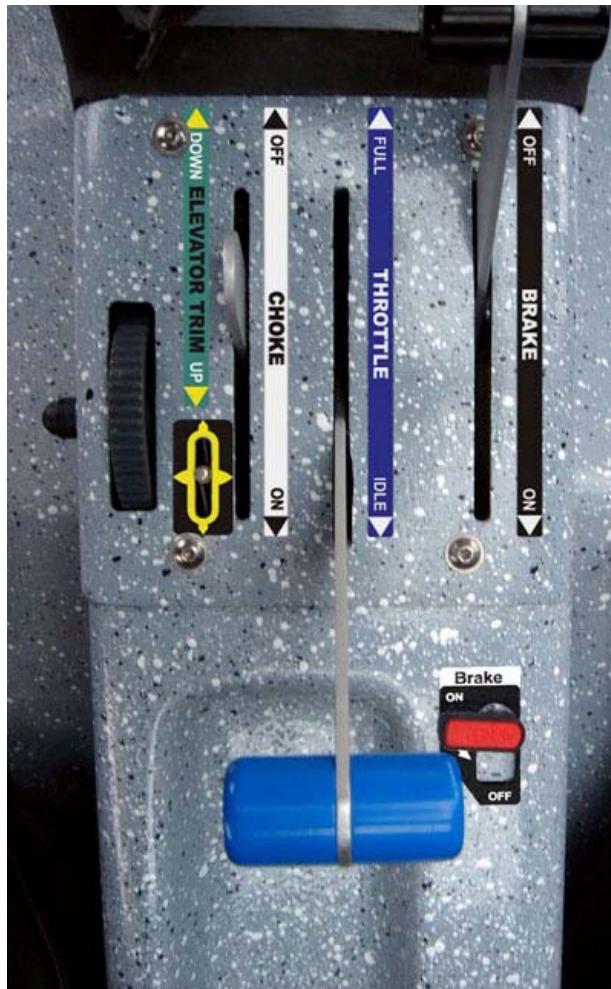

Flap position indicator



Ignition switch and starter



Page Intentionally Left Blank

4 Operating Limitations

4.1 Stalling speeds at maximum takeoff weight (V_{S1} and V_{S0})

V_{S0} : Stalling speed or the minimum steady flight speed in the landing configuration.

V_{S1} : Stalling speed or the minimum steady flight speed obtained in a specific configuration.

V_S	Flaps -6° (-12°)	44 KCAS (49 KCAS)	81 km/h CAS (90 km/h CAS)
V_{S1}	Flaps 0°	42 KCAS	77 km/h CAS
V_{S0}	Flaps 40°	39 KCAS	72 km/h CAS

4.2 Flap extended speed range (V_{S0} to V_{FE})

The White arc on the airspeed indicator is from V_{S0} to V_{FE} , flaps 15° .

V_{FE} : Maximum flap extended speed.

V_{FE} :	Flaps 0°	100 KCAS	185 km/h CAS
	15°	80 KCAS	148 km/h CAS
	30°	62 KCAS	115 km/h CAS
	40°	62 KCAS	115 km/h CAS

4.3 Maximum maneuvering speed (V_A)

V_A : Design maneuvering speed (above this speed only 1/3 of max. deflection may be given, full or abrupt deflection of the control surfaces may cause structural failure).

	LSA registration				BFU / LTF-UL registration		BCAR Section S registration	
	USA		Australia		km/h	kts	km/h	kts
	km/h	kts	km/h	kts				
V_A , CAS	182	98	193	104	193	104	164	89

4.4 Never exceed speed (V_{NE})

V_{NE} : Never-exceed speed.

	LSA registration			
	USA		Australia	
	km/h	kts	km/h	kts
$V_{NE, CAS}$	268 ²	145 ²	301 ¹ /296 ²	163 ¹ /159 ²

	BFU / LTF-UL registration	
	km/h	kts
$V_{NE, CAS}$	276 ³	150 ³

	BCAR Section S registration	
	km/h	kts
$V_{NE, CAS}$	280	151

- 1 - Without rescue system;
- 2 - With BRS 1350 HS.
- 3 - With BRS 1050.

4.5 Crosswind and wind limitations

The maximum demonstrated crosswind is 30 km/h / 16 knots.

CAUTION! Due to the light operating weights and low minimum flight speeds of Light Sport Aircraft, operations with surface winds in excess of 46 km/h / 25 kts should not be attempted.

4.6 Service Ceiling

The Service Ceiling is the maximum altitude at which a climb rate of 100 ft/min / 30 m/min can be achieved. For the CTSW it is 4,250 m / 14,000 feet.

Note: An aircraft must be properly equipped and the pilot appropriately certificated for operations above 10,000 feet / 3,000 m.

4.7 Load factors

The maximum maneuvering limit load factor is:

+ 4 g / -2 g	Flaps up
+ 2 g / -0 g	Flaps down

4.8 Maneuvers

Aerobatics, including intentional spins are prohibited.

4.9 Other limitations

Flight in to known icing is prohibited.

Page Intentionally Left Blank

5 Weight and Balance Information

5.1 Installed equipment list

Please see the Appendix 1.

5.2 Center of gravity (CG) range and determination

Method for determining the Basic Empty Weight

Place the aircraft level on three suitable scales. (If only one scale is available, use leveling blocks and make separate measurements at each gear location).

The aircraft leveling reference is the top of the console (tunnel) that runs between the pilot seats.

Note the following measurements:

- G1: The weight found at the nose wheel location
- G2: The combined weight found at the main wheel locations.
- a: 35.63 in. / 905 mm - the distance from the leading edge of the wing to the nose wheel.
- b: 58.07 in. / 1475 mm - the distance from the main gear location to the nose wheel location.

The Basic empty weight is the total of weights found at G1 and G2

$$G1 + G2 = G$$

Using the following formula, find the Empty Center of Gravity location of the aircraft.

$$((G2 \times b) : G) - a = X$$

X - The distance from the leading edge of the wing to the Cg location

Using the weights found on the scales and the weight and balance sheet determine the Basic Empty Weight.

Complete the Weight & Balance and Equipment List.

Determining the Weight and Balance

Using examples (see Appendix 3), find the loaded center of gravity location.

Using the center of gravity envelope, plot the loaded center of gravity.

Page Intentionally Left Blank

6 Performance

The performance figures are based on sea level, standard atmospheric conditions and a gross weight that depends on your local certification rules.

6.1 Takeoff distance

	600 kg	472,5 kg
Take-off distance over a 15 m / 50ft obstacle	232 m / 760 ft	186 m / 610 ft

6.2 Best rate of climb

At weight 600 kg and flaps 0°:

$V_Y = 154 \text{ km/h} / 78\text{kts}$

6.3 Best angle of climb

At weight 600 kg and flaps 0°:

$V_X = 122 \text{ km/h} / 66 \text{ kts}$

6.4 Cruise speed

Propeller type:

Neuform, 2 blade, 1650 mm dia.

Propeller blade incidence at 3/4*r:

27 deg

Cruise speed at 75% power		
600 kg	-6° (-12°)	205 km/h / 112 kts
472,5 kg	-12°	205 km/h / 112 kts

6.5 RPM

Minimum Idle:

1400

Static:

4700

Normal climb:

4800

Maximum:

5800 (5 min)

Max. continuous:

5500

Normal cruise:

4200 – 5200

Cruise @ 75%:

5200

6.6 Fuel consumption

Fuel consumption in l/h / U.S. gal/h	Rotax 912 UL2	Rotax 912 ULS
at take-off performance	24,0 / 6,3	27,0 / 7,1
at max. continuous performance	22,6 / 5,6	25,0 / 6,6
at 75% continuous performance	16,2 / 4,3	18,5 / 4,9

Page Intentionally Left Blank

7 Emergency Procedures

Engine failure

The first action in case of engine failure is to lower the nose and to establish best glide speed: 115 km/h / 63 kts. If the failure occurs during takeoff, it is often best to attempt a landing straight ahead and under control rather than try to turn and return to the runway. The next action should be to identify a field for landing, taking in to consideration obstacles, field length, and wind direction.

Maintain a minimum speed of 115 km/h / 63 kts at 15° flaps until final approach.

Before touchdown, select flaps 40°.

If there is sufficient time and the failure can be identified, an engine restart while in safe flight altitude may be attempted.

If the restart is successful it may be possible to proceed to a suitable landing area and perform a precautionary landing.

In case of fire shut off the engine:

- Shut off the fuel valve;
- Turn off the ignition;
- Slip away from the fire if possible;
- Land as soon as possible.

The Emergency Parachute System (BRS)

The BRS system may be used at a variety of altitudes and airspeeds. Situations that might warrant its use may include:

- A loss of control in Instrument Meteorological Conditions
- A structural failure
- A collision in flight
- An irrecoverable spin
- Pilot incapacitation
- Jammed flight controls
- Engine failure over hostile terrain

If possible, before activating the BRS shut off the engine and tighten the seatbelts.

To activate the system, pull the T handle all the way to the stop.

CAUTION! The operator of a CTSW must be thoroughly familiar with the contents of the BRS Manual and abide by all instructions and limitations within.

Overturn on land

- Carefully unfasten the seat belts and lower yourself first, then your passenger.
- Be careful of any spilled fuel – there may be a fire hazard!
- Leave the airplane immediately.

Failure of the Dynon EMS

Failure of the Dynon EMS (if equipped) does not directly endanger continuation of flight. With a completely failed EMS system the engine data can no more be surveyed by the pilot. To avoid damages to the engine the flight can be continued, but operation should be limited to moderate RPMs (equalling maximum 185 km/h / 100 kts cruise speed at flaps fully negative). Aerotow or banner tow shall not be done with this failure. Ongoing flights to a qualified service station are allowed with the limitations named before. Before such a flight due care has to be given to oil and coolant quantity checks before the flight.

Flap control failure

If failure of the flap control occurred, proceed a suitable landing area and perform a precautionary landing. Use instruction for the flap manual operation.

Instruction for the flap manual operation

- 1) To activate the manual operation of the flap control printed circuit board (PCB), do as follows.
 - a) Turn the flap control switch by 180° with reference to 15° position to illuminate the LED display VD1 and central segments of the automatic operation indicator (provided the processor is in proper working condition).

This is to notify that the manual operation is switched on and the automatic operation is switched off. The control system is in the stand-by mode.

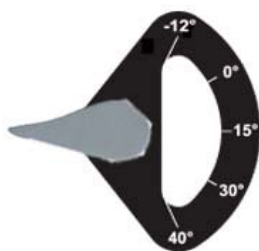

- b) When the flap control switch is turned by 180° with reference to 30° position, the flaps start to retract (flaps move up)

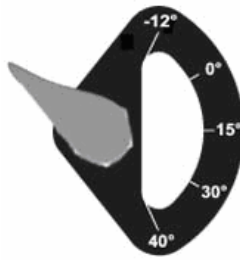

VD2

Located on the plate of the electric mechanism MT-10 is the limit switch which has the function to limit the movement of flaps. This corresponds to the maximum up deflection. When the flaps move, the LED display VD2 illuminates.

c) When the movement of flaps has been accomplished, the control switch should be reset to a neutral position (see item 1, a).

d) When the flap control switch is turned by 180° with reference to 0° position, the flaps start to extend (flaps move down).

At this point, the LED display VD3 illuminates. The limit switch located on the MT-10 has the function to limit the movement of flaps.

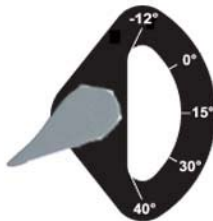

VD3

e) Intermediate flap position (for instance 0°, 15°, 30°) is to be selected by sight according to the position of flaps with respect to the wing.

To set the flaps in intermediate positions, if necessary, ensure that flaps move up or down as far as the required position. After that, stop the movement of flaps by setting the flap control switch in a neutral position (item 1, a).

2) To activate the automatic operation, set the switch in one of the designated positions (-6° (-12°), 0°, 15°, 30°, 40°), accompanied by an indication at the display corresponding to the selected position. The movement of flaps in these positions is to be stopped automatically.

To change the settings of the automatic operation, if necessary, comply with the instructions "Setting-up of flap positions".

Page Intentionally Left Blank

8 Normal Procedures

8.1 Preflight

A. Cabin

- | | |
|-------------------------|----------------------|
| 1. Aircraft documents | Check |
| 2. Flight controls | Free and correct |
| 3. Spar Bolts | Installed and secure |
| 4. Ignition | Off, key out |
| 5. Electrical equipment | Off |
| 6. Radio master | Off |
| 7. Master Switch | On |
| 8. Flaps | Down |
| 9. Master switch | Off |
| 10. Fuel Valve | On |

B. Left side

- | | |
|---------------------------|--------|
| 1. Main gear and tire | Check |
| 2. Baggage compartment | Secure |
| 3. Antenna | Check |
| 4. Aft fuselage condition | Check |
| 5. Tie down | Remove |
| 6. Vertical Stabilizer | Check |
| 7. Stabilator | Check |
| 8. Servo tab | Check |
| 9. Tie-down | Remove |
| 10. Rudder | Check |

C. Right Side

- | | |
|---------------------------|--------|
| 1. Vertical Stabilizer | Check |
| 2. Aft fuselage condition | Check |
| 3. Baggage compartment | Secure |
| 4. Main gear and tire | Check |

D. Left wing

- | | |
|----------------------|--------|
| 1. Flap | Check |
| 2. Aileron | Check |
| 3. Wing tip | Check |
| 4. Wing leading edge | Check |
| 5. Pitot tube | Check |
| 6. Tie down | Remove |
| 7. Fuel cap | Secure |

8. Fuel tank vent Aligned
9. Vent manifold Check

E. Nose

1. Cowling Secure
2. Exhaust stack Secure
3. Nose gear Check
4. Engine intakes Clear
5. Landing Light Check
6. Spinner Secure
7. Propeller Check
8. Cowling Secure
9. Oil quantity Check (follow the Rotax Manual)
10. Fuel Drain and Check
11. Static port Clear

F. Right Wing

1. Leading edge Check
2. Tie down Remove
3. Wing tip Check
4. Aileron Check
5. Flap Check
6. Fuel cap Secure
7. Fuel tank vent Aligned
8. Vent manifold Check

8.2 Engine start

1. Preflight	Complete
2. Parking Brake	Set
3. Carburetor heat	Off
4. Circuit breakers	In
5. Radios and Electrical equipment	Off
6. Master Switch	On
7. Anti-collision lights	On
8. Fuel Valve	Open
9. Ignition key	In
10. Choke	As required
11. Throttle	Closed
12. Ignition Switch	Start and release
13. Choke	Adjust
14. Oil pressure	Check
15. Radios	Set
16. Flaps	Up

8.3 Taxiing

1. Brakes and Steering	Check
------------------------	-------

Before takeoff

1. Parking Brake	Set
2. Seat belts	Secure
3. Doors	Closed
4. Flight Controls	Free and correct
5. Flight Instruments	Set
6. Choke	Off
7. Carburetor heat	Off
8. Throttle	3200 RPM
9. Engine Indications	Check
10. Ignition	Check Left, Right, & Both (max. drop 300 RPM/max diff. 120 RPM)
11. Oil temperature	Min 51°C / 124°F
12. Throttle	Idle
13. Flaps	Set for takeoff
14. Trim	Set for takeoff
15. Radios	Set
16. Parking Brake	Release

8.4 Normal takeoff

- | | | | |
|--------------------|----------|------------------|-----------|
| 1. Flaps | | 0° to 15° | |
| 2. Throttle | | Off | |
| 3. Carburetor heat | | Full | |
| 3. Climb at MTOW: | | | |
| | 600 kg | 78 km/h / 42 kts | flaps 15° |
| | 472,5 kg | 95 km/h / 51 kts | flaps 15° |

8.5 Climb

- | | |
|------------------------------|----------------------------------|
| 1. Power | 5500 RPM (max. continuous) |
| 2. Best angle of climb speed | V _x = 66 kts flaps 0° |
| 3. Best rate of climb speed | V _y = 78 kts flaps 0° |

8.6 Cruise

- | | |
|-----------------------|-------|
| 1. Power | Set |
| 2. Engine Instruments | Check |

8.7 Descent

- | | |
|--------------------|-------------|
| 1. Carburetor heat | As required |
| 2. Altimeter | Set |

8.8 Before landing

- | | |
|--------------------|-------------------|
| 1. Seatbelts | Secure |
| 2. Airspeed | 100 km/h / 54 kts |
| 3. Flaps | 15° to 40° |
| 4. Carburetor heat | Off |

8.9 Normal landing

Flaps as desired, 40° for short field

Airspeed (V_{FE}):

Flaps 0°	100 KCAS	185 km/h CAS
15°	80 KCAS	148 km/h CAS
30°	62 KCAS	115 km/h CAS
40°	62 KCAS	115 km/h CAS

8.10 After landing

- | | |
|------------------|---------|
| 1. Landing light | Off |
| 2. Flaps | Retract |

8.11 Shut down

- | | |
|-------------------------|-----|
| 1. Parking brake | Set |
| 2. Radios | Off |
| 3. Electrical equipment | Off |
| 4. Ignition | Off |
| 5. Master switch | Off |

8.12 Short field takeoff procedure

- | | |
|---------------|------------------|
| Flaps | 15° |
| Parking brake | Set |
| Power | Full |
| Brakes | Release |
| Rotate | 80 km/h / 44 kts |

8.13 Balked landing procedure

- | | |
|----------|-------------------|
| Power | Full |
| Flaps | 15° |
| Airspeed | 110 km/h / 59 kts |

8.14 Information on stalls, spins and other useful pilot information

Stalls

The CTSW exhibits conventional characteristics with a slight buffet at the onset of the stall. There is no tendency to roll in a coordinated stall. Directional control should be maintained through use of the rudder.

Recovery is also conventional: release pressure on the control stick to reduce the angle of attack. Apply full power, and slowly recover.

Spins

The CTSW is not certified for spins.

In the event of an unintentional spin:

1. Reduce power to idle
2. Center the ailerons
3. Apply rudder in the opposite direction of rotation
4. When the rotation stops, smoothly recover from the resultant dive.

If an unintentional spin is entered and the altitude is such that a safe recovery cannot be made, the ballistic parachute system should be deployed.

Steep turns

Enter with coordinated use of rudder and ailerons. Increase pitch and power as necessary to maintain altitude and airspeed. Do not exceed 60° of bank angle.

Page Intentionally Left Blank

9 Aircraft Ground Handling and Servicing

9.1 Servicing fuel, oil and coolant

Fuel

The fuel tanks are equipped with vented fuel caps that are located on the upper surface of the wing. The fuel caps must be in place for flight, with the vents facing forward. A calibrated dip stick, with left tank and right tank indications, is supplied to check the fuel quantity. The aircraft must be grounded during refueling and secured from open flame.

Note: The aircraft finish may be damaged by exposure to fuel; any spills should be immediately cleaned up.

Oil

For an accurate oil measurement:

1. Set the Parking brake.
2. Check the Master switch is off, and the Ignition key is out.
3. Open the top cowling hatch.
4. Open the Oil tank.
5. Turn the propeller 3 to 4 times in the direction of rotation, while you hear the air gurgling in the oil tank.
6. Check the oil level. If it is not sufficient, remove the top cowling and refill the oil tank.

Coolant

To check the coolant level:

1. Set the Parking brake
2. Check the Master switch is off, and the Ignition key is out.
3. Open the top cowling hatch.
4. Check the coolant level. It should be between min. and max. marks.
5. If it is not sufficient, remove the top cowling, open the cap of the coolant tank and add coolant to fill up the tank.
6. Make sure that no air is inside the cooling system.
7. Close the coolant tank cap.
8. If necessary, add coolant to the expansion tank.

9.2 Towing (moving) and tie-down instructions

Moving the CTSW

The aircraft can be moved by one person.

1. Check that the parking brake is off.
2. Check that the area around the aircraft is clear of obstacles and people.
3. Push down on the tail boom of the aircraft to lift the nose gear off the ground.
Be careful not to damage antennas mounted on the fuselage' bottom.
4. Push the aircraft in needed direction.

Tie down instructions

1. Install mooring lines from the ground to the tie-down rings on the undersurface of the wings.
2. Place the tail boom tie-down strap around the tail boom and secure to the ground with mooring lines.
3. Stop wheels with a wheel blocks.

Page Intentionally Left Blank

10 Required Placards and Markings

10.1 Airspeed indicator range markings

Aircrafts with LSA registration

Marking	Speed Range	
White range (flap operating range)	72 ... 115 km/h	39 ... 62 kts
Green range (normal operating range)	81 [91*]..222 km/h	44 [49*]... 120 kts
Yellow range (caution range)	222 ... 269 km/h	120 ... 145 kts
Red line (never exceed speed)	269 km/h	145 kts

* - with flaps in (-12°) position

Aircrafts with LTF registration

Marking	Speed Range	
White range (flap operating range)	72 ... 115 km/h	39 ... 62 kts
Green range (normal operating range)	94 ... 245 km/h	51 ... 132 kts
Yellow range (caution range)	245 ... 260 km/h	132 ... 140 kts
Red line (never exceed speed)	301 km/h	163 kts

Aircrafts with BCAR Section S registration

Marking	Speed Range	
White range (flap operating range)	61 ... 122 km/h	33 ... 66 kts
Green range (normal operating range)	74 ... 219 km/h	40 ... 118 kts
Yellow range (caution range)	219 ... 278 km/h	118 ... 150 kts
Red line (never exceed speed)	278 km/h	150 kts

10.2 Operating limitations on instrument panel

MAX: RPM 5800, EGT 1616F, CHT 248F, Oil Temp. 266F, Oil Press. 102 psi

or

MAX: RPM 5800, EGT 880°C, CHT 120°C, Oil Temp. 130°C, Oil Press. 7 bar

10.3 Passenger Warning

The warning* “This aircraft was manufactured in accordance with Light Sport Aircraft airworthiness standards and does not conform to standard category airworthiness requirements” is placed on the instrument panel or in a place where a passenger will see it.

* - actual for aircrafts with LSA registration only

10.4 “NO INTENTIONAL SPINS”

The placard “NO INTENTIONAL SPINS” is placed close to the airspeed indicator.

NO INTENTIONAL SPINS

10.5 Miscellaneous placards and markings

Type of Fuel

2 x beside filling cap

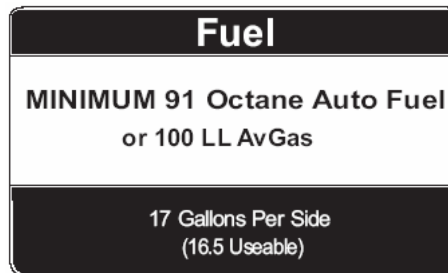

Red marking
Red marking
Red marking
Red marking

5800 RPM
5 bar
130°C
120°C

Tachometer
oil pressure gauge
oil temperature gauge
water temp gauge (cylinder head)

Oil pressure gauge

max 102 psi 7 bar
min 12 psi 0,8 bar

Throttle

lever box



Choke

lever box



Stabilator Trim

lever box



Brakes

lever box



Flaps

-6° (-12°), 0°, 15°, 30°, 40°

flap indicator

Oil quality

Cowling hatch backside

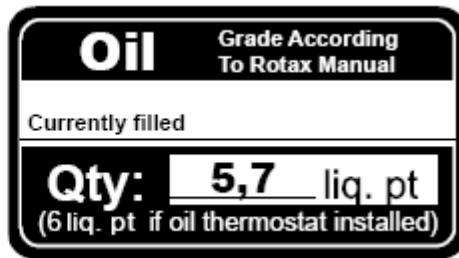
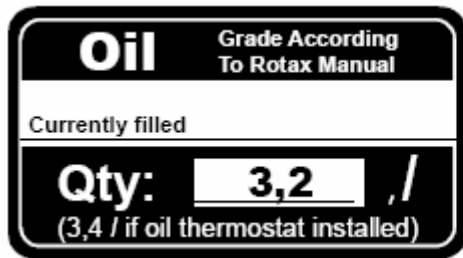

Circuit Breakers

right side of the central console

Main Circuit Breakers

right side of the Central console

Fuses

Switch panel (Middle Console, depends on panel type)

Main fuses

Instrument panel

Maintenance/packing interval

BRS Manual & Chute placard

Baggage Compartment

Baggage area

<p>Baggage Compartment max. 55 lbs. each side 25 kg.</p>

Doors

External door side, under the window



Internal door side, under the window

<p>OPEN Do Not Open Doors In-Flight CLOSED</p>

Page Intentionally Left Blank

11 Supplementary Information

11.1 Familiarization flight procedures

See the Pilot Training Supplement for familiarization procedures*.

* - actual for aircrafts with LSA registration only

11.2 Pilot operating advisories

None at this time.

Page Intentionally Left Blank

12 List of amendments

Revision No.	Date released	Affected chapters	Affected pages	Approved by
Original Issue	28-Feb-2005	N/A	N/A	
1	20-Jun-2005	2 General Information	6; 8	
		3 Airplane and Systems Descriptions	13; 14	
		4 Operating Limitations	15; 17; 19	
		10 Required Placards and Markings	36	
2	05-Oct-2005	4.5 Crosswind and wind limitations	15	
		6 Performance	27	
		8.2 Engine starting	31	
		8.4 Normal takeoff	32	
		8.5 Best angle of climb speed (V _x); 8.6 Cruise	33	
		10.5 Miscellaneous placards and markings	36	
3	05-Apr-2006	Total revised; Name of document changed; insert part 12, Appendix 1, Appendix 2, Appendix 3, Appendix 4	1-62	
4	05-Dec-06	Added "Failure of the Dynon EMS" paragraph	29	
5	30-Dec-06	Document fully revised	1 -APP3-3	
5a	16-Apr-07	Oil characteristics updated	3-3	
		Point 3.5 carried to page 3-4	3-4	
		Never exceed speed values updated	4-2	
		Green range for LSA airplanes updated	10-1	
5b	13-Jul-07	Corrected airspeed for US-LSA version from 113 kts to 98 kts	4-2	
		List of amendments added	12-1, 12-2	
6	07-Feb-08	Name of document changed	i	
		App. 1 changed	1	
		App. 2 changed	2	

Appendix 1. Equipment List

USA: Please see document "Product Description CT LSA. Flight Design"

Europe: Please see document "Product Description CT Ultralight. Flight Design"

Appendix 2. Variants of instrument panels

Symbolic notations

- 1 Dynon EFIS 100 Flight information system
- 2 Dynon EMS 120 Engine monitoring system
- 3 Autopilot CT Pilot 2 Axis (Digiflight II)
- 4 Air Speed Indicator
- 5 Altimeter
- 6 Radio Garmin SL series & Transponder GTX series
- 7 Radio King KY series & Transponder KT series
- 8 GPS Garmin 496
- 9 -
- 10 Air speed indicator D 80mm
- 11 Three pointer altimeter D 80mm
- 12 Variometer D 57mm
- 13 Slip & bank indicator
- 14 UMA analogs (RPM meter, Oil pressure, Oil temperature, Cylinder head water temperature, Volt meter*)
- 15 Hobbs hour counter
- 16 Trutrack ADI

* - Volt meter excluded on CTSW Classic Light ready to fly modification.

CTSW Classic Light

CTSW Classic Light base instrument panel



CTSW Classic Light additionally equipped with Honeywell Radio and Transponder



CTSW Classic Light additionally equipped with Garmin Radio and Transponder



CTSW Classic

CTSW Classic base instrument panel



CTSW Classic additionally equipped with Autopilot, Nightflight package with TruTrack ADI, Garmin GPS, Radio and Transponder



CTSW Advanced

CTSW Advanced (Dynon) instrument panel



CTSW Advanced additionally equipped with Autopilot, Nightflight package, Garmin GPS, Radio and Transponder



Appendix 3. Samples of the Weight & Balance and Equipment List

Sample of the Weight & Balance and Equipment List for aircrafts with LSA registration

Weight and Balance			CTSW Classic			Tricycle Gear AC		
Weight	Model	Serial-Nr	Name	Model	Producer	C.g. position, in	Weight, lb	Moment, lb*in
	0X-0X-0X		ASI	6FMS443	Winter	-4.72	0.48	-2.29
	5X4X0X0		Altimeter	ALT20INF-3	FALCON GAUGE	-4.72	1.34	-6.35
			Compass	Airpath	Airpath Instrument CO	-3.94	0.59	-2.34
			Varimeter/VSI	8-210-20	U.M.A., INC	-4.33	0.48	-2.10
			Tachometer	19-519-211	U.M.A., INC	-5.12	0.31	-1.58
			Radio	KY97ATSO	Bendix/King	-11.42	3.96	-45.27
			Oilpressure gauge	N04113V130P070	U.M.A., INC	-5.12	0.26	-1.35
			Oiltemp gauge	N12113V300F0A0	U.M.A., INC	-5.12	0.26	-1.35
			Watertemp gauge	N12116V300F020	U.M.A., INC	-5.12	0.26	-1.35
			Battery	SBS 8	HAWKER	-22.83	6.06	-138.32
			Rescue system	BRS-6 1350HS	BRS	48.03	33.04	1586.94
			Fly.Dat					
			Clock		Hobbs	-5.12	0.22	-1.13
			AI (Horizon)					
			Transponder	KT76ATSO	Bendix/King	-11.42	2.20	-25.15
			Turn and Bank					
			GPS					
			ELT	AK-450	AMERI-King Co	63.39	3.77	238.74
			Towhook					
			Autopilot					
			Voltmeter	N141100917V060	U.M.A., INC	-5.12	0.24	-1.24
			Altitude holder					
Empty weight definition								

Weight (lbs.)	Arm (in.)	Moment (lb*in)
Empty weight	11.8	
Fuel (34.32 gal Max)	20.5	
Pilot (Min 120 lbs. Max 260 lbs.)	20.5	
Passenger (Max 260 lbs.)	43.0	
Port Baggage (55 lbs. max)	43.0	
Starboard Baggage (65 lbs. max)	43.0	
Gross (1320 lbs. max)		
Take Off Weight (1320 max)		
Flight CG Range (13.28-18.7)		

Weight*Arm=Moment Total Moment / Total Weight = CG

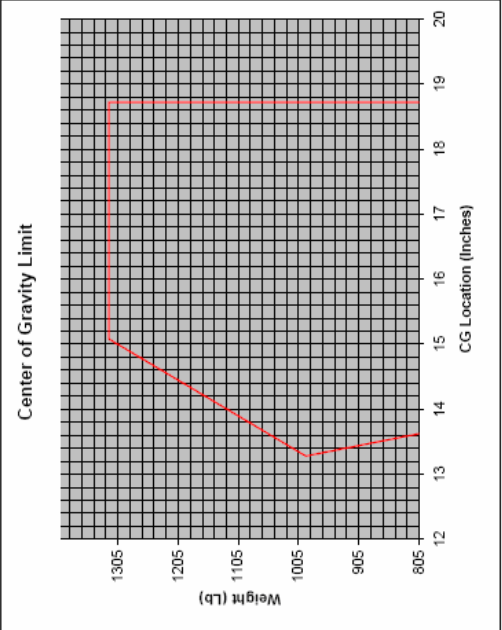

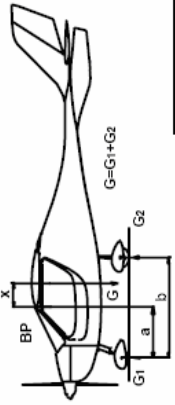

Reference	gross (lb)	tare (lb)	net (lb)	Arm (in)
from G1			112.8	57.48
from G2			603.5	716.3
Weight G=				
CG empty (in) according G2/b/G-a=				
empty CG limits from...9.45...to...14.17				

Fedchun _____ Location Kherson, Ukraine
 Weighed by _____ Date 12/0X/200X

The acceptable empty Cg range is 9.45 to 14.17 inches.

Weight & Balance and Equipment List				Tricycle Gear AC			
Weight and Balance Sheet	Model	Name	Model	Producer	C.g. position, m	Weight, kg	Moment, kg*m
	CTSW Classic	ASI	6FMS443	Winter	-0.12	0.22	-0.026
	DX-0X-0X	Altimeter	ALT20INF-3	FALCON GAUGE	-0.12	0.61	-0.073
	5X4X0X0	Compass	Airpath	Airpath Instrument CO	-0.1	0.27	-0.027
Datum: Leading Edge		Variometer/VSI	8-210-20	U.M.A., INC	-0.11	0.22	-0.024
Leveling: Top of fuselage tunnel		Tachometer	19-519-211	U.M.A., INC	-0.13	0.14	-0.018
		Radio	KY97ATSO	Bendix/King	-0.29	1.8	-0.522
		Oilpressure gauge	N04113V130P070	U.M.A., INC	-0.13	0.12	-0.018
		Oiltemp gauge	N12113V300F0A0	U.M.A., INC	-0.13	0.12	-0.018
		Watertemp gauge	N12116V300F020	U.M.A., INC	-0.13	0.12	-0.018
		Battery	SBS 8	HAWKER	-0.58	2.75	-1.595
		Rescue system	BRS-6 1350HS	BRS	1.22	15.0	18.300
		Fly Dat					
		Clock		Hobbs	-0.13	0.10	-0.013
		AI (Horizon)					
		Transponder	KT76ATSO	Bendix/King	-0.29	1.0	-0.280
		Turn and Bank					
		GPS					
		ELT	AK-450	AMERI-King Co	1.61	1.71	2.753
		Towhook					
		Autopilot					
		Voltmeter	N141100917V060	U.M.A., INC	-0.13	0.11	-0.014
		Altitude holder					
		Empty weight definition					

Weight and Balance Sheet	Weight (kg)	Arm (m)	Moment (kg*m)
Empty weight			
Fuel (93 kg Max)		0.30	
Pilot (Min 54 kg Max 118 kg)		0.52	
Passenger (Max 118 kg)		0.52	
Port Baggage (25 kg max)		1.09	
Starboard Baggage (25 kg max)		1.09	
Gross (600 kg max)			
Take Off Weight (600 max)			
Flight CG (RANGE 0.337-0.478 m)			

Weight*Arm=Moment Total Moment / Total Weight = CG

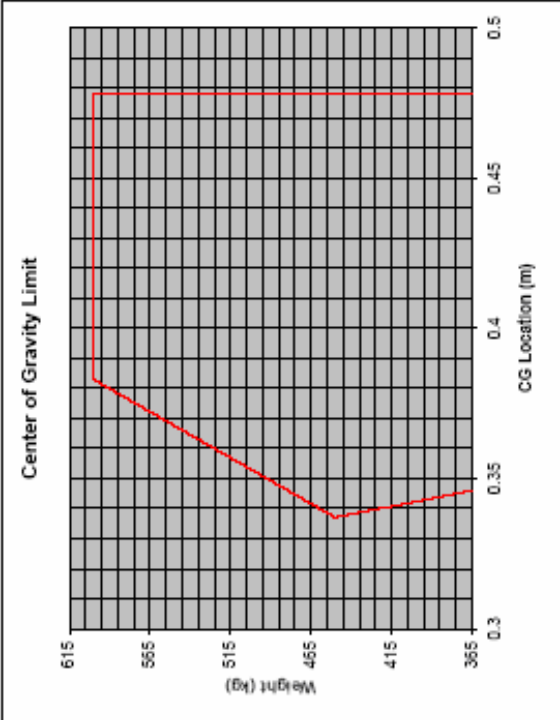

Reference	gross (kg)	tare (kg)	net (kg)
from G1			51.2
from G2			274
			325.2
			345

CG empty (mm) according G2*b/G-a=
empty CG limits from...240...to...360

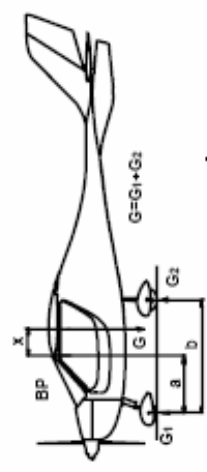

Arm (mm)	a	b
	885	1460

Weight G=
CG empty (mm) according G2*b/G-a=
empty CG limits from...240...to...360

Fedchun _____ Location Kherson, Ukraine
Weighed by _____ Date 12/0X/200X

The acceptable empty Cg range is 240 to 360 mm.

Sample of the Weight & Balance and Equipment List for aircrafts with BFU / LTF-UL registration

Weight and Balance Sheet		Weight & Balance and Equipment List		Tricycle Gear AC	
Model	CTSW Classic	Name	ASI	Producer	Winter
Serial-Nr	XX-1X-2X	Altimeter	6FMS441	Winter	-120
Motor-Nr.	4X3X4X5	Compass	Airpath	Airpath Instrument CO	-120
Technical data according data sheet		Variometer/VS			100
Datum:		Tachometer			
Leveling:		Radio	AR4201	BECKER	-220
Item	kg	Oilpressure gauge			
Wing right	35,5	Oiltemp gauge			
Wing left	35,7	Watertemp gauge			
Fuselage	217,1	Battery	SBS 8	HAWKER	-580
Elevator	9,3	Rescue system			
Rudder	2,2	Fly-Dat	Fly-Dat	ROTAX	-190
Wing struts (50%)		Clock			
useful load		AI (Horizon)			
total weight	299,8	Transponder	BXP6401-2-(01)	BECKER	-230
		Slip		Winter	-100
		GPS			
		ELT			
		Towhook			
		Autopilot			
		Voltmeter			

Empty weight	299,8 kg
Useful load	172,7 kg
MTOW	472,5 kg
Weight NWCP incl. useful load	401,3 kg

Arm (mm)	
a	875
b	1445

Reference	gross (kg)	tare (kg)	net (kg)
from G1			64,9
from G2			234,9
Weight G=			299,8

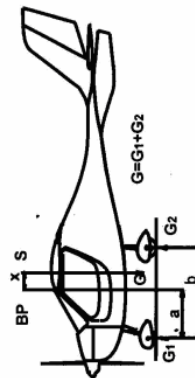

CG empty according $G2*b/G-a=$

empty CG limits from...240...to...360...at

Fedchun 12/0X/200X
 Weighed by Date

The acceptable empty Cg range is 240 to 360 mm.